

# Solutions to the exercises

- 1.1 (a)** True:  $-2$  is an integer.  
**(b)** False:  $5$  is a natural number.  
**(c)** False:  $1.3$  is the rational number  $\frac{13}{10}$ .  
**(d)** False:  $\frac{1}{2}$  is not a natural number.  
**(e)** True:  $-\pi$  is a real number.  
**(f)** True:  $2$  is a rational number ( $\frac{2}{1}$ ).

- 1.2 (a)** True:  $1$  is a member of the set given.  
**(b)** True: the set  $\{-9\}$  is a member of the set given.  
**(c)** False: the number  $9$  belongs to the set given, but the set  $\{9\}$  does not.  
**(d)** False:  $(0, 1)$  is not a member of the set given.  
**(e)** True: the set  $\{0, 1\}$  is a member of the set given.

- 1.3 (a)**  $\{k \in \mathbb{Z} : -2 < k < 1000\}$   
**(b)**  $\{x \in \mathbb{R} : 2 \leq x \leq 7\}$   
**(c)**  $\{x \in \mathbb{Q} : x > 0 \text{ and } x^2 > 2\}$   
**(d)**  $\{2n : n \in \mathbb{N}\}$   
**(e)**  $\{2^k : k \in \mathbb{Z}\}$

**1.4 (a)**  $l = \{(x, y) \in \mathbb{R}^2 : y = 2x + 5\}$

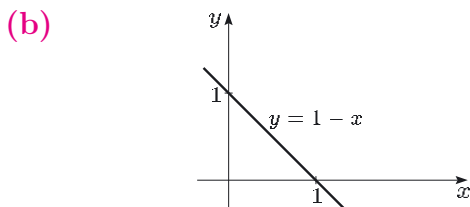

**1.5 (a)**  $C = \{(x, y) \in \mathbb{R}^2 : (x - 1)^2 + (y + 4)^2 = 9\}$

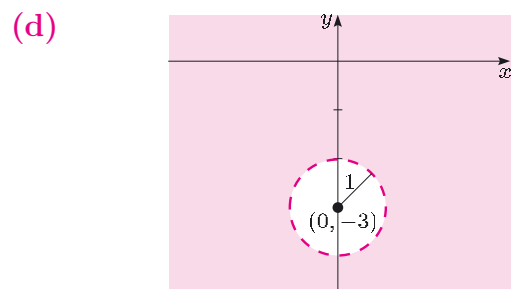
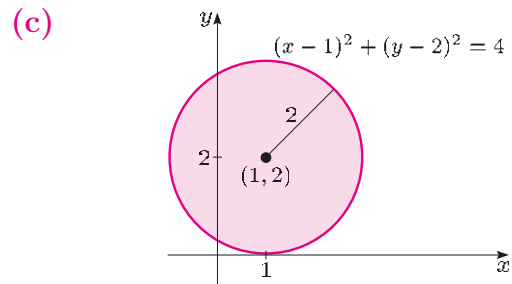
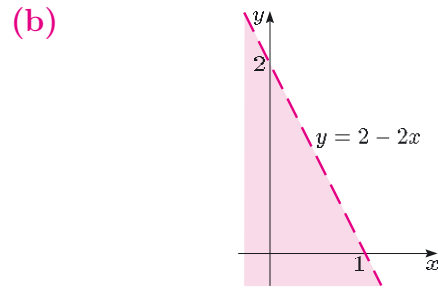
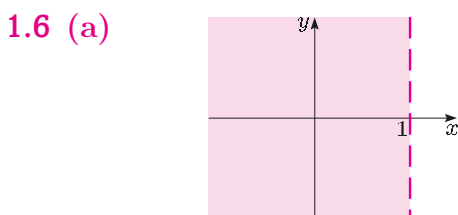
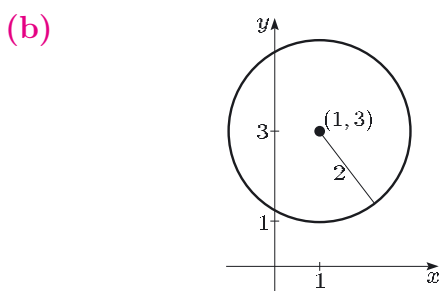

**1.7 (a)**  $\{(x, y) \in \mathbb{R}^2 : 0 \leq x \leq 2, 1 \leq y \leq 3\}$

**(b)**  $\{(x, y) \in \mathbb{R}^2 : x \geq 0, y = 2x^2 + 1\}$

**1.8 (a)** The set  $B$  consists of the solutions of the equation

$$x^2 + x - 6 = 0,$$

which we can write as

$$(x - 2)(x + 3) = 0.$$

So  $B = \{2, -3\} = A$ .

**(b)**  $A = \{k \in \mathbb{Z} : k \text{ is odd and } 2 < k < 10\}$   
 $= \{3, 5, 7, 9\},$

$$B = \{n \in \mathbb{N} : n \text{ is a prime number and } n < 10\}$$

$$= \{2, 3, 5, 7\}.$$

Hence  $A \neq B$ , either because  $2 \in B$  but  $2 \notin A$ , or because  $9 \in A$  but  $9 \notin B$ .

**1.9 (a)** We calculate  $x - 4y$  using the coordinates of each point of  $A$ :

$$5 - 4 \times 2 = -3,$$

$$1 - 4 \times 1 = -3,$$

$$-3 - 4 \times 0 = -3.$$

This shows that each element of  $A$  is an element of  $B$ , so  $A \subseteq B$ .

**(b)** The set  $A$  is the interior of the unit circle, and  $B$  is the half-plane consisting of all points with negative  $y$ -coordinate. So  $A \not\subseteq B$ , because, for example, the point  $(\frac{1}{2}, \frac{1}{2})$  belongs to  $A$  but not to  $B$ .

**1.10** We showed that  $A \subseteq B$  in the solution to Exercise 1.9(a). Also, for example, the point  $(9, 3)$  lies in  $B$ , since

$$9 - 4 \times 3 = -3,$$

but does not lie in  $A$ . Therefore  $A$  is a proper subset of  $B$ .

**1.11** First we show that  $A \subseteq B$ .

Let  $(x, y) \in A$ ; then  $x = t^2$  and  $y = 2t$ , for some  $t \in \mathbb{R}$ . Hence  $y^2 = 4t^2 = 4x$ . So  $(x, y) \in B$ , and so  $A \subseteq B$ .

Next we show that  $B \subseteq A$ .

Let  $(x, y) \in B$ . We must show that  $(x, y) \in A$ . Let  $t = \frac{1}{2}y$ ; then  $x = \frac{1}{4}y^2 = (\frac{1}{2}y)^2 = t^2$ , and  $y = 2t$ . So  $(x, y) = (t^2, 2t) \in A$ , and so  $B \subseteq A$ .

Since  $A \subseteq B$  and  $B \subseteq A$ , it follows that  $A = B$ .

**1.12**

$k$	Subsets of $\{1, 2, 3, 4\}$ of size $k$
0	$\emptyset$
1	$\{1\}, \{2\}, \{3\}, \{4\}$
2	$\{1, 2\}, \{1, 3\}, \{1, 4\}, \{2, 3\}, \{2, 4\}, \{3, 4\}$
3	$\{1, 2, 3\}, \{1, 2, 4\}, \{1, 3, 4\}, \{2, 3, 4\}$
4	$\{1, 2, 3, 4\}$

The table shows that the set  $\{1, 2, 3, 4\}$  has  $1 + 4 + 6 + 4 + 1 = 16$  subsets in all.

**1.13**  $\binom{10}{2} = \frac{10!}{2!8!} = \frac{10 \times 9}{2} = 5 \times 9 = 45,$   
 $\binom{10}{3} = \frac{10!}{3!7!} = \frac{10 \times 9 \times 8}{3 \times 2} = 10 \times 3 \times 4 = 120,$   
 $\binom{11}{3} = \frac{11!}{3!8!} = \frac{11 \times 10 \times 9}{3 \times 2} = 11 \times 5 \times 3 = 165.$

Hence  $\binom{10}{2} + \binom{10}{3} = \binom{11}{3}.$

**1.14 (a)**  $\binom{n}{n-k} = \frac{n!}{(n-k)!k!}$  and  
 $\binom{n}{k} = \frac{n!}{k!(n-k)!},$  so  $\binom{n}{n-k} = \binom{n}{k}.$

**(b)** We can interpret the identity as follows.

$\binom{n}{k}$  is the number of ways of *choosing*  $k$  elements from  $n$ , which is the same as  $\binom{n}{n-k}$ , the number of ways of *excluding*  $k$  elements from  $n$ .

**1.15 (a)**  $(1, 7) \cup [4, 11] = (1, 11].$

**(b)** The domain of  $f$  is the set  $\{x \in \mathbb{R} : x^2 - 9 > 0\} = \{x \in \mathbb{R} : x < -3 \text{ or } x > 3\},$  that is,  $(-\infty, -3) \cup (3, \infty).$

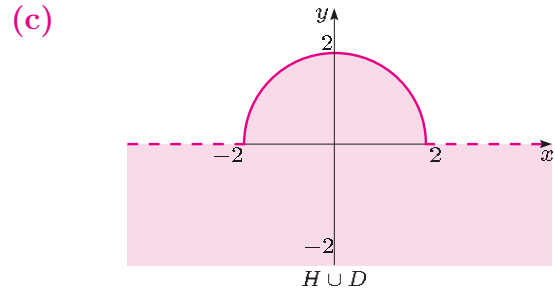

**1.16 (a)**  $(1, 7) \cap [4, 11] = [4, 7].$

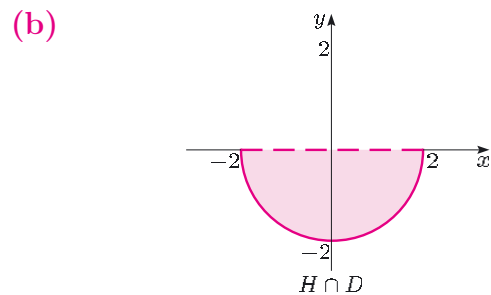

**1.17 (a)**  $(1, 7) - [4, 11] = (1, 4)$  and  $[4, 11] - (1, 7) = [7, 11].$

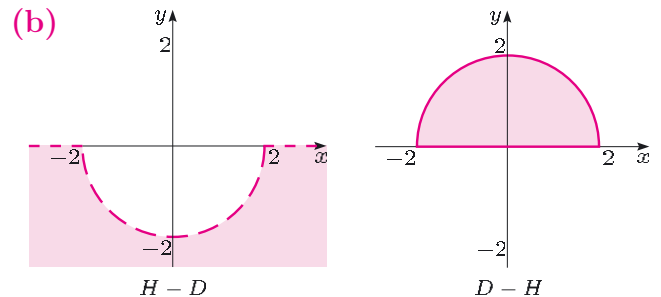

**1.18 (a)** False: 0 is not a natural number.

**(b)** True: 0 is a rational number.

**(c)** False:  $-0.6$  is a real number.

**(d)** True: 37 is an integer.

**(e)** False: 20 is not a member of the set given.

**(f)** True: the set  $\{1, 2\}$  is the same as the set  $\{2, 1\}.$

**(g)** False:  $\emptyset$  does not contain any elements.

**1.19 (a)** The elements are 3, 4, 5, 6. Note that 2 and 7 are not included.

**(b)** The elements are  $-1, -4.$  These are the solutions of the equation.

**(c)** The only element is 5. The equation has two solutions,  $-5$  and  $5,$  but only  $5 \in \mathbb{N}.$

**1.20** In each case, you may have found a different expression for the same set.

(a)  $\{k \in \mathbb{Z} : -20 < k < -3\}$

(b)  $\{3k : k \in \mathbb{Z}, k \neq 0\}$

(c)  $\{x \in \mathbb{R} : x > 15\}$

**1.21 (a)**

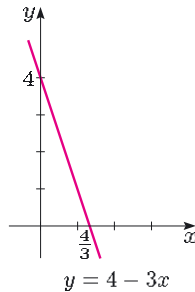

(b)

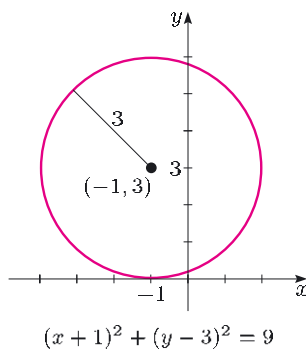

(c)

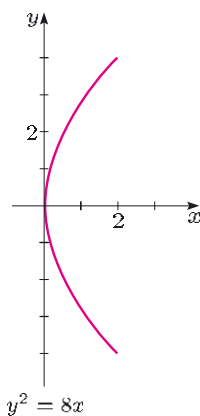

**1.22 (a)**

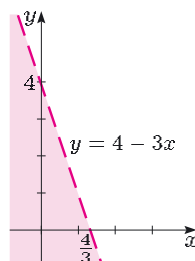

The line is not part of the set.

(b)

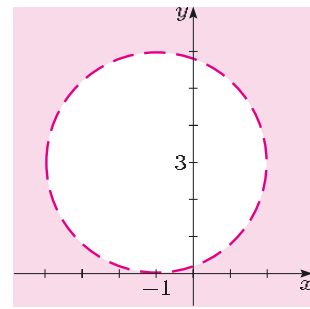

The circle is not part of the set.

(c)

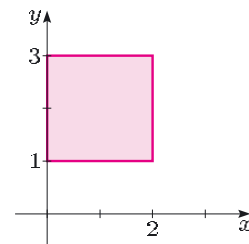

The edges of the square belong to the set.

**1.23 (a)**  $(0, 0)$ ,  $(0, 6)$  and  $(-4, 6)$  all satisfy the equation  $(x + 2)^2 + (y - 3)^2 = 13$ , so  $A \subseteq B$ .

(b) The point  $(1, 0)$  belongs to  $A$  but not to  $B$ , so  $A$  is not a subset of  $B$ .

(c) If  $x = 2 \cos t$  and  $y = 3 \sin t$ , then  $\frac{x^2}{4} + \frac{y^2}{9} = 1$ , so  $A \subseteq B$ .

**1.24** We must first show that  $A \subseteq B$ . Let  $(x, y)$  be an arbitrary element of  $A$ ; then  $x^2 + 4y^2 < 1$ . Since  $x^2 \geq 0$  for all  $x \in \mathbb{R}$ , this implies that  $4y^2 < 1$ , and hence  $y^2 < \frac{1}{4}$ . Hence  $y < \frac{1}{2}$ . Thus  $(x, y) \in B$ .

To confirm that  $A$  is a *proper* subset of  $B$ , we must show that there is an element of  $B$  that does not lie in  $A$ . The point  $(1, -1)$ , for example, lies in  $B$ , since  $-1 < \frac{1}{2}$ , but does not lie in  $A$ , since

$$1^2 + 4(-1)^2 = 5,$$

which is not less than 1. Therefore  $A$  is a proper subset of  $B$ .

**1.25 (a)** 1, -1, 2 are the three solutions of  $x^3 - 2x^2 - x + 2 = 0$ , so  $A = B$ .

(b) We showed in the solution to Exercise 1.23(c) that  $A \subseteq B$ .

If  $\frac{x^2}{4} + \frac{y^2}{9} = 1$ , then  $(x/2, y/3)$  lies on the unit circle, so we can find  $t \in [0, 2\pi]$  such that  $x/2 = \cos t$  and  $y/3 = \sin t$ . Hence  $x = 2 \cos t$  and  $y = 3 \sin t$ , so  $B \subseteq A$ .

Since  $A \subseteq B$  and  $B \subseteq A$ , it follows that  $A = B$ .

(c) The set  $B$  contains some negative numbers (for example, -1) which cannot be expressed as  $\frac{p}{q}$  for  $p, q \in \mathbb{N}$ . Hence  $A \neq B$ .

**1.26 (a)**  $A \cup B = \{0, 2, 4, 5, 6\}$ ,

$$A \cap B = \{4\},$$

$$A - B = \{0, 2\}.$$

**(b)**  $A \cup B = (-5, 17]$ ,

$$A \cap B = [2, 3],$$

$$A - B = (-5, 2).$$

**(c)**  $A \cup B = B$ ,

$$A \cap B = A,$$

$$A - B = \emptyset.$$

**2.1 (a)** This is a translation of the plane that moves each point to the right by 2 units and up by 3 units.

**(b)** This is a reflection of the plane in the  $x$ -axis.

**(c)** This is a rotation of the plane through  $\pi/2$  anticlockwise about the origin.

**2.2** Only diagram (b) corresponds to a function.

Diagram (a) does not correspond to a function, as there is no arrow from the element 3.

Diagram (c) does not correspond to a function, as there are two arrows from the element 1.

**2.3** The images of the elements of  $A$  are

$$f(0) = 9, f(1) = 8, f(2) = 7, f(3) = 6, f(4) = 5,$$

$$f(5) = 4, f(6) = 3, f(7) = 2, f(8) = 1, f(9) = 0.$$

So the image of  $f$  is  $\{0, 1, 2, 3, 4, 5, 6, 7, 8, 9\} = A$ .

**2.4** Only diagram (a) corresponds to an onto function.

Diagram (b) does not even correspond to a function, as there is no arrow from the element 4.

Diagram (c) corresponds to a function that is not onto, as there is no arrow going to the element 1.

**2.5 (a)** The sketch of the graph of  $f$  below suggests that  $f(\mathbb{R}) = [1, \infty)$ .

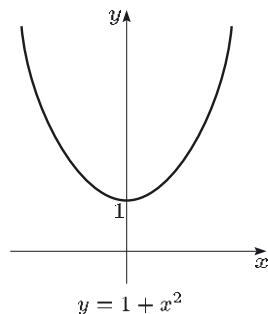

Let  $x \in \mathbb{R}$ ; then  $f(x) = 1 + x^2$ . Since  $x^2 \geq 0$ , we have  $1 + x^2 \geq 1$  and so  $f(\mathbb{R}) \subseteq [1, \infty)$ .

We must show that  $f(\mathbb{R}) \supseteq [1, \infty)$ .

Let  $y \in [1, \infty)$ . We must show that there exists  $x \in \mathbb{R}$  such that  $f(x) = y$ ; that is,  $1 + x^2 = y$ .

Now  $x = \sqrt{y-1}$  is real, since  $y \geq 1$ , and satisfies  $f(x) = y$ , as required. (Alternatively,  $x = -\sqrt{y-1}$  is real and satisfies  $f(x) = y$ .)

Thus  $f(\mathbb{R}) \supseteq [1, \infty)$ .

Since  $f(\mathbb{R}) \subseteq [1, \infty)$  and  $f(\mathbb{R}) \supseteq [1, \infty)$ , it follows that  $f(\mathbb{R}) = [1, \infty)$ , so the image of  $f$  is  $[1, \infty)$ , as expected.

The interval  $[1, \infty)$  is not the whole of the codomain  $\mathbb{R}$ , so  $f$  is not onto.

**(b)** This function is a reflection of the plane in the  $x$ -axis. This suggests that  $f(\mathbb{R}^2) = \mathbb{R}^2$ . We know that  $f(\mathbb{R}^2) \subseteq \mathbb{R}^2$ , so we must show that  $f(\mathbb{R}^2) \supseteq \mathbb{R}^2$ .

Let  $(x', y') \in \mathbb{R}^2$ . We must show that there exists  $(x, y) \in \mathbb{R}^2$  such that  $f(x, y) = (x', y')$ ; that is,

$$x' = x, \quad y' = -y.$$

Rearranging these equations, we obtain

$$x = x', \quad y = -y'.$$

Let  $(x, y) = (x', -y')$ ; then  $(x, y) \in \mathbb{R}^2$  and  $f(x, y) = (x', y')$ , as required.

Thus  $f(\mathbb{R}^2) \supseteq \mathbb{R}^2$ .

Since  $f(\mathbb{R}^2) \subseteq \mathbb{R}^2$  and  $f(\mathbb{R}^2) \supseteq \mathbb{R}^2$ , it follows that  $f(\mathbb{R}^2) = \mathbb{R}^2$ , so the image of  $f$  is  $\mathbb{R}^2$ , as expected.

The codomain of  $f$  is also  $\mathbb{R}^2$ , so  $f$  is onto.

**2.6** Only diagram (c) corresponds to a one-one function.

Diagram (a) corresponds to a function that is not one-one, as there are two arrows going to the element 3.

Diagram (b) does not even correspond to a function, as there is no arrow from the element 2.

**2.7 (a)** This function is not one-one since, for example,

$$f(2) = f(-2) = 1 + 4 = 5.$$

**(b)** This function is a reflection of the plane in the  $x$ -axis, so we expect it to be one-one. We now prove this algebraically.

Suppose that  $f(x_1, y_1) = f(x_2, y_2)$ ; then

$$(x_1, -y_1) = (x_2, -y_2).$$

Thus

$$x_1 = x_2 \quad \text{and} \quad -y_1 = -y_2.$$

So

$$y_1 = y_2.$$

Hence  $(x_1, y_1) = (x_2, y_2)$ , so  $f$  is one-one.

**2.8 (a)** In Exercise 2.7 we saw that  $f$  is not one-one, so  $f$  does not have an inverse function.

**(b)** In Exercise 2.7 we saw that  $f$  is one-one, so  $f$  has an inverse function.

In Exercise 2.5 we saw that the image of  $f$  is  $\mathbb{R}^2$  and, for each  $(x', y') \in \mathbb{R}^2$ , we have

$$(x', y') = f(x', -y').$$

So  $f^{-1}$  is the function

$$f^{-1} : \mathbb{R}^2 \longrightarrow \mathbb{R}^2 \\ (x', y') \longmapsto (x', -y').$$

This can be expressed in terms of  $x$  and  $y$  as

$$f^{-1} : \mathbb{R}^2 \longrightarrow \mathbb{R}^2 \\ (x, y) \longmapsto (x, -y).$$

(In this case,  $f^{-1}$  is actually equal to  $f$ .)

**(c)** This is a linear function, which suggests that it is one-one. First we confirm this algebraically.

Suppose that  $f(x_1) = f(x_2)$ ; then

$$8x_1 + 3 = 8x_2 + 3,$$

so  $8x_1 = 8x_2$ , and hence  $x_1 = x_2$ . Thus  $f$  is one-one, and so it has an inverse function. We now find the image of  $f$ . We suspect that its image is  $\mathbb{R}$ , so we now prove this algebraically. Let  $y$  be an arbitrary element in  $\mathbb{R}$ . We must show that there exists an element  $x$  in the domain  $\mathbb{R}$  such that

$$f(x) = y; \quad \text{that is, } 8x + 3 = y.$$

Rearranging this equation, we obtain

$$x = \frac{y - 3}{8}.$$

This is in  $\mathbb{R}$  and satisfies  $f(x) = y$ , as required. Thus the image of  $f$  is  $\mathbb{R}$ .

Hence  $f^{-1}$  is the function

$$f^{-1} : \mathbb{R} \longrightarrow \mathbb{R} \\ y \longmapsto \frac{y - 3}{8}.$$

This can be expressed in terms of  $x$  as

$$f^{-1} : \mathbb{R} \longrightarrow \mathbb{R} \\ x \longmapsto \frac{x - 3}{8}.$$

**2.9 (a)** The function

$$g : [0, \infty) \longrightarrow \mathbb{R} \\ x \longmapsto |x|$$

is a restriction of  $f$  that is one-one.

(There are many other possibilities.)

**2.10 (a)** The rule of  $g \circ f$  is

$$(g \circ f)(x) = g(f(x)) = g(-x) \\ = 3(-x) + 1 \\ = -3x + 1.$$

Thus  $g \circ f$  is the function

$$g \circ f : \mathbb{R} \longrightarrow \mathbb{R} \\ x \longmapsto -3x + 1.$$

**(b)** The rule of  $f \circ g$  is

$$(f \circ g)(x) = f(g(x)) = f(3x + 1) \\ = -(3x + 1) \\ = -3x - 1.$$

Thus  $f \circ g$  is the function

$$f \circ g : \mathbb{R} \longrightarrow \mathbb{R} \\ x \longmapsto -3x - 1.$$

**2.11** The rule of  $f \circ g$  is

$$(f \circ g)(x, y) = f(g(x, y)) = f(-x, y) \\ = (-x, -y).$$

Thus  $f \circ g$  is the function

$$f \circ g : \mathbb{R}^2 \longrightarrow \mathbb{R}^2 \\ (x, y) \longmapsto (-x, -y).$$

(In this case,  $f \circ g = g \circ f$ .)

**2.12** The rule of  $g \circ f$  is

$$(g \circ f)(x) = g(f(x)) = g(3x + 1) \\ = \frac{3}{(3x + 1) + 2} \\ = \frac{1}{x + 1}.$$

The domain of  $g \circ f$  is

$$\{x \in [-1, 1] : f(x) \in \mathbb{R} - \{-2\}\}.$$

If  $x \in [-1, 1]$ , then  $f(x) \in \mathbb{R} - \{-2\}$  unless  $f(x) = -2$ . Now  $f(x) = -2$  when

$$3x + 1 = -2,$$

that is, when

$$x = -1.$$

So the domain of  $g \circ f$  is

$$[-1, 1] - \{-1\} = (-1, 1].$$

Thus  $g \circ f$  is the function

$$g \circ f : (-1, 1] \longrightarrow \mathbb{R} \\ x \longmapsto \frac{1}{x + 1}.$$

**2.13** For each  $x \in \mathbb{R}$ , we have

$$\begin{aligned} f(g(x)) &= f(x - 3) \\ &= (x - 3) + 3 \\ &= x; \end{aligned}$$

that is,  $f \circ g = i_{\mathbb{R}}$ .

For each  $x \in \mathbb{R}$ , we have

$$\begin{aligned} g(f(x)) &= g(x + 3) \\ &= (x + 3) - 3 \\ &= x; \end{aligned}$$

that is,  $g \circ f = i_{\mathbb{R}}$ .

Since  $g \circ f = i_{\mathbb{R}}$  and  $f \circ g = i_{\mathbb{R}}$ , it follows that  $g$  is the inverse function of  $f$ .

**2.14 (a)** This function is a *rotation* of the plane through  $3\pi/2$  anticlockwise about the origin.

**(b)** This function is a *translation* of the plane that moves each point to the left by 2 units and up by 1 unit.

**2.15 (a)**

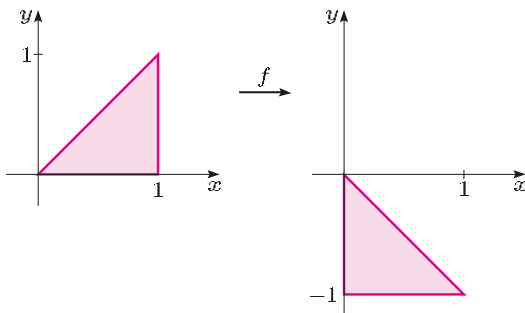

**(b)**

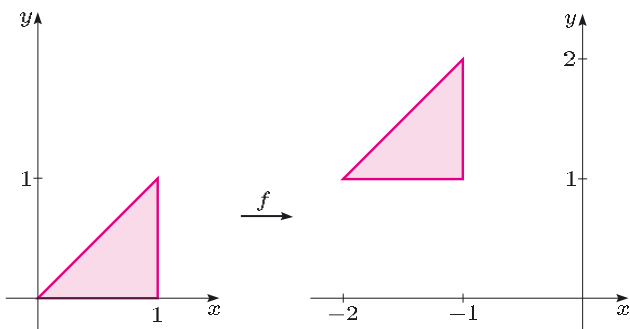

**2.16 (a)** This function is a rotation (see Exercise 1(c)) so we expect to find that  $f(\mathbb{R}^2) = \mathbb{R}^2$ .

Let  $(x, y) \in \mathbb{R}^2$ ; then  $f(x, y) = (-y, x) \in \mathbb{R}^2$ , so  $f(\mathbb{R}^2) \subseteq \mathbb{R}^2$ .

We must now show that  $f(\mathbb{R}^2) \supseteq \mathbb{R}^2$ .

Let  $(x', y') \in \mathbb{R}^2$ . We must show that there exists  $(x, y) \in \mathbb{R}^2$  such that  $f(x, y) = (x', y')$ , that is,

$$x' = -y \quad \text{and} \quad y' = x.$$

Rearranging these equations, we obtain

$$x = y' \quad \text{and} \quad y = -x'.$$

So, for each  $(x', y') \in \mathbb{R}^2$ , we have

$$(x', y') = f(y', -x'),$$

thus  $f(\mathbb{R}^2) \supseteq \mathbb{R}^2$ .

Since  $f(\mathbb{R}^2) \subseteq \mathbb{R}^2$  and  $f(\mathbb{R}^2) \supseteq \mathbb{R}^2$ , it follows that  $f(\mathbb{R}^2) = \mathbb{R}^2$ , so  $f$  is onto.

**(b)**

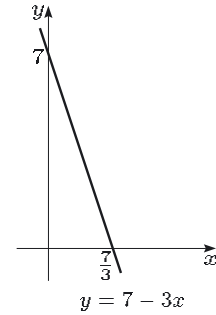

The graph above suggests that  $f(\mathbb{R}) = \mathbb{R}$ . We now prove this algebraically.

Let  $x \in \mathbb{R}$ ; then  $7 - 3x \in \mathbb{R}$ , so  $f(\mathbb{R}) \subseteq \mathbb{R}$ .

Let  $y \in \mathbb{R}$ ; then we want to find  $x \in \mathbb{R}$  such that  $y = 7 - 3x$ .

This gives  $x = \frac{7 - y}{3}$ , which is in  $\mathbb{R}$ , so for each  $y \in \mathbb{R}$

we have  $y = f\left(\frac{7 - y}{3}\right)$ . So  $f(\mathbb{R}) \supseteq \mathbb{R}$ .

Since  $f(\mathbb{R}) \subseteq \mathbb{R}$  and  $f(\mathbb{R}) \supseteq \mathbb{R}$ , it follows that  $f(\mathbb{R}) = \mathbb{R}$ , so  $f$  is onto.

**(c)**

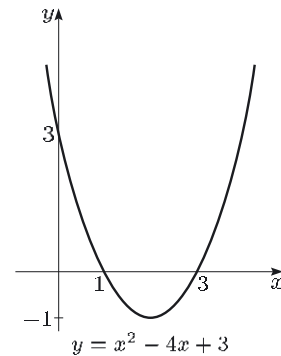

The graph above suggests that  $f(\mathbb{R}) = [-1, \infty)$ . We now prove this algebraically.

Let  $x \in \mathbb{R}$ ; then

$$\begin{aligned} f(x) &= x^2 - 4x + 3 \\ &= (x - 2)^2 - 1 \geq -1. \end{aligned}$$

So  $f(\mathbb{R}) \subseteq [-1, \infty)$ .

Let  $y \in [-1, \infty)$ . We must show that there exists  $x \in \mathbb{R}$  such that  $f(x) = y$ , that is,

$$x^2 - 4x + 3 = y.$$

This means that

$$(x - 2)^2 = y + 1,$$

and we can take  $x = 2 + \sqrt{y + 1}$ , which is in  $\mathbb{R}$  since  $y + 1 \geq 0$ .

So, for each  $y \in [-1, \infty)$ , we have  $y = f(2 + \sqrt{y+1})$ .

Hence  $f(\mathbb{R}) \supseteq [-1, \infty)$ .

Since  $f(\mathbb{R}) \subseteq [-1, \infty)$  and  $f(\mathbb{R}) \supseteq [-1, \infty)$ , it follows that  $f(\mathbb{R}) = [-1, \infty)$ .

Since  $f(\mathbb{R}) \neq \mathbb{R}$ ,  $f$  is not onto.

(d)

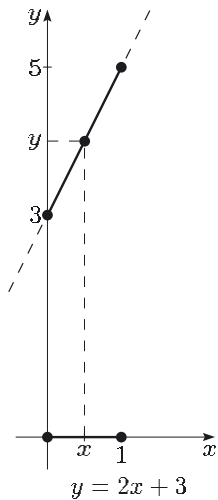

The graph above suggests that  $f([0, 1]) = [3, 5]$ . We now prove this algebraically.

Let  $x \in [0, 1]$ . Then  $0 \leq x \leq 1$ , so  $0 \leq 2x \leq 2$ , so  $3 \leq 2x + 3 \leq 5$ . Hence  $f(x) \in [3, 5]$ . Thus  $f([0, 1]) \subseteq [3, 5]$ .

Let  $y \in [3, 5]$ ; then we want to find  $x \in [0, 1]$  such that  $y = 2x + 3$ . This gives  $x = \frac{y-3}{2}$ . Now

$3 \leq y \leq 5$ , so  $0 \leq y - 3 \leq 2$ , so  $0 \leq \frac{y-3}{2} \leq 1$ . Thus

$\frac{y-3}{2} \in [0, 1]$ , as required. So for each  $y \in [3, 5]$  we

have  $y = f\left(\frac{y-3}{2}\right)$ , where  $\frac{y-3}{2} \in [0, 1]$ . So  $f([0, 1]) \supseteq [3, 5]$ .

Since  $f([0, 1]) \subseteq [3, 5]$  and  $f([0, 1]) \supseteq [3, 5]$ , it follows that  $f([0, 1]) = [3, 5]$ . So  $f$  is not onto.

**2.17 (a)** This function  $f$  is a rotation of the plane, so we expect  $f$  to be one-one. We now prove this algebraically.

Suppose that  $f(x_1, y_1) = f(x_2, y_2)$ ; then

$$(-y_1, x_1) = (-y_2, x_2),$$

so

$$-y_1 = -y_2 \quad \text{and} \quad x_1 = x_2.$$

Thus  $(x_1, y_1) = (x_2, y_2)$ , so  $f$  is one-one.

(b) The graph in the solution to Exercise 2.16(b) suggests that  $f$  is one-one. We prove this algebraically.

Suppose that  $f(x_1) = f(x_2)$ ; then

$$7 - 3x_1 = 7 - 3x_2.$$

Thus  $x_1 = x_2$ , so  $f$  is one-one.

(c) The graph in the solution to Exercise 2.16(c) suggests that  $f$  is not one-one. To show that this is so, we find two points in the domain of  $f$  with the same image. For example,

$$f(0) = f(4) = 3,$$

so  $f$  is not one-one.

(d) The graph in the solution to Exercise 2.16(d) suggests that  $f$  is one-one. We prove this algebraically.

Suppose that  $f(x_1) = f(x_2)$ ; then

$$2x_1 + 3 = 2x_2 + 3.$$

Thus  $x_1 = x_2$ , so  $f$  is one-one.

**2.18 (a)** We have shown in Exercise 2.17(a) that  $f$  is one-one, so  $f$  has an inverse, and we have shown in the solution to Exercise 2.16(a) that

$$(x', y') = f(y', -x'),$$

so the inverse of  $f$  is the function

$$f^{-1} : \mathbb{R}^2 \longrightarrow \mathbb{R}^2$$

$$(x', y') \longmapsto (y', -x').$$

This can be expressed in terms of  $x$  and  $y$  as

$$f^{-1} : \mathbb{R}^2 \longrightarrow \mathbb{R}^2$$

$$(x, y) \longmapsto (y, -x).$$

(b) We have shown in the solutions to Exercises 2.16(b) and 2.17(b) that  $f$  is one-one and that

$$y = f\left(\frac{7-y}{3}\right), \quad \text{for } y \in \mathbb{R}.$$

Hence  $f$  has an inverse

$$f^{-1} : \mathbb{R} \longrightarrow \mathbb{R}$$

$$y \longmapsto \frac{7-y}{3}.$$

This can be expressed in terms of  $x$  as

$$f^{-1} : \mathbb{R} \longrightarrow \mathbb{R}$$

$$x \longmapsto \frac{7-x}{3}.$$

(c) We have shown in Exercise 2.17(c) that  $f$  is not one-one, so  $f$  does not have an inverse.

(d) We have shown in the solutions to Exercises 2.16(d) and 2.17(d) that  $f$  is one-one and that the image of  $f$  is  $[3, 5]$ . We also showed that

$$y = f\left(\frac{y-3}{2}\right), \quad \text{for } y \in [3, 5].$$

Hence  $f$  has an inverse

$$f^{-1} : [3, 5] \longrightarrow [0, 1]$$

$$y \longmapsto \frac{y-3}{2}.$$

This can be expressed in terms of  $x$  as

$$f^{-1} : [3, 5] \longrightarrow [0, 1]$$

$$x \longmapsto \frac{x-3}{2}.$$

**2.19 (a)** Since any number in the domain of  $g$  has an image under  $g$  which is in  $\mathbb{R}$ , and hence in the domain of  $f$ , the domain of  $f \circ g$  is the domain of  $g$ . Also,

$$(f \circ g)(x) = f\left(\frac{1}{x^2 - 4}\right) = 7 - 3\left(\frac{1}{x^2 - 4}\right).$$

Hence the composite is the function

$$f \circ g: \mathbb{R} - \{2, -2\} \longrightarrow \mathbb{R} \\ x \longmapsto 7 - \frac{3}{x^2 - 4}.$$

**(b)** Since any point in the domain of  $g$  has an image under  $g$  which is in  $\mathbb{R}^2$ , and hence in the domain of  $f$ , the domain of  $f \circ g$  is the domain of  $g$ .

Also,

$$(f \circ g)(x, y) = f(y, x) = (-x, y).$$

Hence the composite is the function

$$f \circ g: \mathbb{R}^2 \longrightarrow \mathbb{R}^2 \\ (x, y) \longmapsto (-x, y).$$

**3.1 (a)** The negation can be expressed as ‘ $x = \frac{3}{5}$  is not a solution of the equation  $3x + 5 = 0$ ’.

**(b)** The negation can be expressed as ‘ $\pi$  is greater than or equal to 5’.

**(c)** The negation can be expressed as ‘there is no integer that is divisible by 3 but not by 6’, or, alternatively, ‘every integer that is divisible by 3 is also divisible by 6’.

**(d)** The negation can be expressed as ‘there is a real number  $x$  that does not satisfy the inequality  $x^2 \geq 0$ ’.

**(e)** The negation can be expressed as ‘at least one of the integers  $m$  and  $n$  is even’.

**(f)** The negation can be expressed as ‘the integers  $m$  and  $n$  are both even’.

**3.2 (a)** The statement can be rewritten as ‘if  $x^2 - 2x + 1 = 0$ , then  $(x - 1)^2 = 0$ ’. This is true.

**(b)** The statement can be rewritten as ‘if  $n$  is odd, then  $n^3$  is odd’. This is true.

**(c)** The statement can be rewritten as ‘if a given integer is divisible by 3, then it is also divisible by 6’. This is false.

**(d)** The statement can be rewritten as ‘if  $x > 2$ , then  $x > 4$ ’. This is false.

**3.3 (a)** The converse is ‘if  $m + n$  is even, then  $m$  and  $n$  are both odd’. The given statement is true, and its converse is false.

**(b)** The converse is ‘if  $m + n$  is odd, then one of the pair  $m, n$  is even and the other is odd’. The given statement and its converse are both true.

**3.4 (a)** The two implications are ‘if the product  $mn$  is odd, then both  $m$  and  $n$  are odd’, and ‘if both  $m$  and  $n$  are odd, then the product  $mn$  is odd’. Both implications are true, so the equivalence is true.

**(b)** The two implications are ‘if the product  $mn$  is even, then both  $m$  and  $n$  are even’, and ‘if both  $m$  and  $n$  are even, then the product  $mn$  is even’. The first implication is false, and the second is true. The equivalence is false.

**3.5 (a)** Suppose that  $n$  is an even integer. Then  $n = 2k$ , where  $k \in \mathbb{Z}$ , so

$$n^2 = (2k)^2 = 4k^2 = 2(2k^2).$$

Hence  $n^2$  is even, as required.

**(b)** Let  $m$  and  $n$  be multiples of  $k$ . Then  $m = ka$  and  $n = kb$ , where  $a$  and  $b$  are integers. Hence

$$m + n = ka + kb = k(a + b).$$

Since  $a + b$  is an integer, we deduce that  $m + n$  is a multiple of  $k$ , as required.

**(c)** Suppose that one of the pair  $m, n$  is even and the other is odd. Then one of them is equal to  $2k$  and the other to  $2l + 1$ , for some integers  $k$  and  $l$ . Then

$$m + n = 2k + (2l + 1) = 2(k + l) + 1,$$

which shows that  $m + n$  is odd.

**(d)** Let  $n$  be a positive integer. We note that

$$n^2 + n = n(n + 1).$$

Either  $n$  or  $n + 1$  must be even, so  $n^2 + n$  is even, as required.

(Alternatively, the implication can be proved by considering two separate cases: the case where  $n$  is even, and the case where  $n$  is odd. However the above proof is shorter and simpler.)

**3.6 (a)** Taking  $m = 1$  and  $n = 3$  provides a counter-example, since then  $m + n = 4$ , which is even.

**(b)** The number  $-3$  is a counter-example, because  $-3 < 2$  but  $((-3)^2 - 2)^2 = (9 - 2)^2 = 7^2 = 49$ , which is not less than 4.

**(c)** We look for a counter-example. Here is a table for the first few values of  $n$ .

$n$	1	2	3
$4^n + 1$	5	17	65

Since  $4^3 + 1 = 65$  is not a prime number, it provides a counter-example, so this implication is false.

**3.7 (a)** Let  $P(n)$  be the statement

$$1 + 2 + \cdots + n = \frac{1}{2}n(n + 1).$$

Then  $P(1)$  is true, since  $1 = \frac{1}{2}1(1 + 1)$ .

Let  $k \geq 1$ , and assume that  $P(k)$  is true:

$$1 + 2 + \cdots + k = \frac{1}{2}k(k + 1).$$



We wish to deduce that  $P(k+1)$  is true:

$$1 + 2 + \cdots + k + (k+1) = \frac{1}{2}(k+1)(k+2).$$

Now

$$\begin{aligned} 1 + 2 + \cdots + k + (k+1) &= \frac{1}{2}k(k+1) + (k+1) \quad (\text{by } P(k)) \\ &= (k+1)\left(\frac{1}{2}k+1\right) \\ &= \frac{1}{2}(k+1)(k+2). \end{aligned}$$

Thus, for  $k = 1, 2, \dots$ ,

$$P(k) \Rightarrow P(k+1).$$

Hence, by mathematical induction,  $P(n)$  is true for  $n = 1, 2, \dots$ .

**(b)** Let  $P(n)$  be the statement

$$1^3 + 2^3 + \cdots + n^3 = \frac{1}{4}n^2(n+1)^2.$$

Then  $P(1)$  is true, since

$$1^3 = 1 \quad \text{and} \quad \frac{1}{4}1^2(1+1)^2 = 1.$$

Let  $k \geq 1$ , and assume that  $P(k)$  is true:

$$1^3 + 2^3 + \cdots + k^3 = \frac{1}{4}k^2(k+1)^2.$$

We wish to deduce that  $P(k+1)$  is true:

$$1^3 + 2^3 + \cdots + k^3 + (k+1)^3 = \frac{1}{4}(k+1)^2(k+2)^2.$$

Now

$$\begin{aligned} 1^3 + 2^3 + \cdots + k^3 + (k+1)^3 &= \frac{1}{4}k^2(k+1)^2 + (k+1)^3 \quad (\text{by } P(k)) \\ &= (k+1)^2\left(\frac{1}{4}k^2 + (k+1)\right) \\ &= \frac{1}{4}(k+1)^2(k^2 + 4k + 4) \\ &= \frac{1}{4}(k+1)^2(k+2)^2. \end{aligned}$$

Thus, for  $k = 1, 2, \dots$ ,

$$P(k) \Rightarrow P(k+1).$$

Hence, by mathematical induction,  $P(n)$  is true for  $n = 1, 2, \dots$ .

**3.8 (a)** Let  $P(n)$  be the statement ' $4^{2n-3} + 1$  is a multiple of 5'.

Then  $P(2)$  is true, because  $4^{2 \times 2 - 3} + 1 = 4^1 + 1 = 5$ .

Now let  $k \geq 2$ , and assume that  $P(k)$  is true; that is,

$$4^{2k-3} + 1 \text{ is a multiple of } 5.$$

We wish to deduce that  $P(k+1)$  is true; that is,

$$4^{2(k+1)-3} + 1 = 4^{2k-1} + 1 \text{ is a multiple of } 5.$$

Now

$$\begin{aligned} 4^{2k-1} + 1 &= 4^2 4^{2k-3} + 1 \\ &= 16 \times 4^{2k-3} + 1 \\ &= 15 \times 4^{2k-3} + 4^{2k-3} + 1. \end{aligned}$$

The first term here is a multiple of 5, and  $4^{2k-3} + 1$  is a multiple of 5, by  $P(k)$ . Therefore  $4^{2k-1} + 1$  is a multiple of 5. Hence

$$P(k) \Rightarrow P(k+1), \text{ for } k = 2, 3, \dots$$

Hence, by mathematical induction,  $P(n)$  is true, for  $n = 2, 3, \dots$ .

**(b)** Let  $P(n)$  be the statement  $5^n < n!$ .

Then  $P(12)$  is true, because  $5^{12} = 2.44 \times 10^8$  and  $12! = 4.79 \times 10^8$ , both to three significant figures.

Now let  $k \geq 12$ , and assume that  $P(k)$  is true; that is,

$$5^k < k!.$$

We wish to deduce that  $P(k+1)$  is true; that is,

$$5^{(k+1)} < (k+1)!.$$

Now

$$\begin{aligned} 5^{k+1} &= 5 \times 5^k \\ &< 5 \times k! \quad (\text{by } P(k)) \\ &< (k+1)k! \\ &= (k+1)!, \end{aligned}$$

where we have used the fact that  $k \geq 12$ , so  $k+1 \geq 13 > 5$ . Hence

$$P(k) \Rightarrow P(k+1), \text{ for } k = 12, 13, \dots$$

Hence, by mathematical induction,  $P(n)$  is true, for  $n = 12, 13, \dots$ .

**3.9 (a)** Suppose that there exist real numbers  $a$  and  $b$  with  $ab > \frac{1}{2}(a^2 + b^2)$ . Then  $a^2 - 2ab + b^2 < 0$ ; that is,  $(a-b)^2 < 0$ . This is a contradiction, so our supposition must be false. Hence there are no such real numbers  $a$  and  $b$ .

**(b)** Suppose that there exist integers  $m$  and  $n$  with  $5m + 15n = 357$ . The left-hand side of this equation is a multiple of 5, so the right-hand side is also. But this is a contradiction, so our supposition must be false. Hence there are no such integers  $m$  and  $n$ .

**3.10** Suppose that  $n = a + 2b$ , where  $a$  and  $b$  are positive real numbers. Suppose also that  $a < \frac{1}{2}n$  and  $b < \frac{1}{4}n$ . Then

$$n = a + 2b < \frac{1}{2}n + 2\left(\frac{1}{4}n\right) = n.$$

This contradiction shows that the supposition that  $a < \frac{1}{2}n$  and  $b < \frac{1}{4}n$  must be false; that is we must have  $a \geq \frac{1}{2}n$  or  $b \geq \frac{1}{4}n$ .

**3.11 (a)** We prove the contrapositive implication, which is

$$n \text{ is odd} \Rightarrow n^3 \text{ is odd.}$$

Suppose that  $n$  is odd. Then  $n = 2k + 1$  for some integer  $k$ . Then

$$\begin{aligned} n^3 &= (2k+1)^3 \\ &= (2k+1)(4k^2 + 4k + 1) \\ &= 8k^3 + 12k^2 + 6k + 1 \\ &= 2(4k^3 + 6k^2 + 3k) + 1, \end{aligned}$$

which is odd.

**(b)** We prove the contrapositive implication, which is ‘if at least one of  $m$  and  $n$  is even, then  $mn$  is even’.

Suppose that at least one of  $m$  and  $n$  is even; without loss of generality, we can take it to be  $m$  (since otherwise we can just interchange  $m$  and  $n$ ). Then  $m = 2k$  for some integer  $k$ . Hence  $mn = 2kn$ , which is even.

**(c)** Let  $n$  be an integer which is greater than 1. We prove the contrapositive implication, which is ‘if  $n$  is not a prime number, then  $n$  is divisible by at least one of the primes less than or equal to  $\sqrt{n}$ ’.

Suppose that  $n$  is not a prime number. Then  $n = ab$  for some integers  $a, b$ , where  $1 < a, b < n$ . By the result of Example 3.15, at least one of  $a$  and  $b$  is less than or equal to  $\sqrt{n}$ . This number has a prime factor, which must also be less than or equal to  $\sqrt{n}$ , and this prime factor must also be a factor of  $n$ . This proves the required contrapositive implication.

**3.12** (a), (b) and (c) all have the same meaning. (d) and (f) have the same meaning.

(You may like to show that (a) is true, and hence that (b) and (c) are true; that (d) and (f) are true, but (e) is false.)

**3.13**  $13^2 = 169$  and  $17^2 = 289$ , so we need check only the primes 2, 3, 5, 7, 11, 13.

221 is divisible by 13 ( $221 = 13 \times 17$ ), so it is not prime.

223 is not divisible by any of 2, 3, 5, 7, 11 and 13, so it is prime.

**3.14 (a)** This statement is true.

We have

$$n^3 - n = n(n^2 - 1) = n(n - 1)(n + 1).$$

Either  $n$  is even or  $n + 1$  is even, so  $n^3 - n$  is even.

**(b)** This statement is false.

For example,  $6 + 4$  is a multiple of 5, but 6 and 4 are not multiples of 5.

**(c)** This statement is false.

For example, if  $\theta = \pi/2$ , then

$$\sin 2\theta = \sin \pi = 0,$$

but

$$2 \sin \theta = 2 \sin(\pi/2) = 2.$$

**(d)** This statement is false.

For example,  $f(0) = f(2) = 1$ .

**(e)** This statement is true.

We show that  $f \circ g$  is the identity on  $\mathbb{R} - \{0\}$  and that  $g \circ f$  is the identity on  $\mathbb{R} - \{1\}$ .

We have

$$(f \circ g)(x) = f\left(1 + \frac{1}{x}\right) = \frac{1}{\left(1 + \frac{1}{x}\right) - 1} = x$$

and

$$f \circ g: \mathbb{R} - \{0\} \longrightarrow \mathbb{R} - \{0\}.$$

Also,

$$(g \circ f)(x) = g\left(\frac{1}{x-1}\right) = 1 + \frac{1}{1/(x-1)} = 1 + x - 1 = x$$

and

$$g \circ f: \mathbb{R} - \{1\} \longrightarrow \mathbb{R} - \{1\}.$$

Hence, from Strategy 2.1,  $g$  is the inverse of  $f$ .

**3.15 (a)** The converse is as follows.

If  $m - n$  is an even integer, then  $m$  and  $n$  are both even integers.

**(b)** The original statement is true.

Suppose that  $m$  and  $n$  are both even; then

$$m = 2p, \quad n = 2q, \quad \text{where } p, q \text{ are integers.}$$

Then

$$\begin{aligned} m - n &= 2p - 2q \\ &= 2(p - q), \end{aligned}$$

which is even.

The converse is false.

For example,

$$\begin{aligned} 7 - 3 &= 4 \text{ is even,} \\ \text{but } 7 \text{ and } 3 &\text{ are both odd.} \end{aligned}$$

**3.16 (a)** Let  $P(n)$  be the statement

$$\frac{1}{1 \times 2} + \frac{1}{2 \times 3} + \cdots + \frac{1}{(n-1)n} = \frac{n-1}{n}.$$

Then  $P(2)$  is true, since

$$\frac{1}{1 \times 2} = \frac{1}{2} = \frac{2-1}{2}.$$

Assume that  $P(k)$  is true:

$$\frac{1}{1 \times 2} + \frac{1}{2 \times 3} + \cdots + \frac{1}{(k-1)k} = \frac{k-1}{k}.$$

We wish to deduce that  $P(k+1)$  is true:

$$\begin{aligned} \frac{1}{1 \times 2} + \frac{1}{2 \times 3} + \cdots + \frac{1}{(k-1)k} + \frac{1}{k(k+1)} \\ = \frac{k}{k+1}. \end{aligned}$$

Now

$$\begin{aligned} \frac{1}{1 \times 2} + \frac{1}{2 \times 3} + \cdots + \frac{1}{(k-1)k} + \frac{1}{k(k+1)} \\ = \frac{k-1}{k} + \frac{1}{k(k+1)} \quad (\text{by } P(k)) \\ = \frac{(k-1)(k+1) + 1}{k(k+1)} \\ = \frac{k^2}{k(k+1)} = \frac{k}{k+1}. \end{aligned}$$

Thus, for  $k = 2, 3, \dots$ ,

$$P(k) \Rightarrow P(k+1).$$

Hence, by mathematical induction,  $P(n)$  is true for  $n = 2, 3, \dots$

**(b)** Let  $P(n)$  be the statement

$$3^{2n} - 1 \text{ is divisible by } 8.$$

Then  $P(1)$  is true, since

$$3^2 - 1 = 9 - 1 = 8,$$

which is divisible by 8.

Assume that  $P(k)$  is true:

$$3^{2k} - 1 \text{ is divisible by } 8.$$

We wish to deduce that  $P(k+1)$  is true:

$$3^{2(k+1)} - 1 \text{ is divisible by } 8.$$

Now

$$\begin{aligned} 3^{2(k+1)} - 1 &= 3^2 3^{2k} - 1 \\ &= 9 \times 3^{2k} - 1 \\ &= 8 \times 3^{2k} + (3^{2k} - 1), \end{aligned}$$

which is also divisible by 8, since  $P(k)$  is true.

Thus, for  $k = 1, 2, \dots$ ,

$$P(k) \Rightarrow P(k+1).$$

Hence, by mathematical induction,  $P(n)$  is true for  $n = 1, 2, \dots$

**3.17** Suppose that the given statement is false; that is, there are real numbers  $a$  and  $b$  for which

$$(a+b)^2 < 4ab.$$

Then

$$a^2 + 2ab + b^2 < 4ab,$$

so

$$a^2 - 2ab + b^2 < 0,$$

so

$$(a-b)^2 < 0.$$

But  $(a-b)^2$  is a square, so cannot be negative. This is a contradiction, so the given statement must be true.

Hence

$$(a+b)^2 \geq 4ab \quad \text{for all real numbers } a \text{ and } b.$$

**3.18 (a)** The contrapositive is as follows.

If  $n$  is not divisible by 3,  
then  $n^2$  is not divisible by 3.

**(b)** Suppose that  $n$  is not divisible by 3. Then

$$n = 3k + 1 \quad \text{or} \quad n = 3k + 2,$$

for some integer  $k$ .

If  $n = 3k + 1$ , then

$$\begin{aligned} n^2 &= 9k^2 + 6k + 1 \\ &= 3k(3k + 2) + 1, \end{aligned}$$

which is not divisible by 3.

If  $n = 3k + 2$ , then

$$\begin{aligned} n^2 &= 9k^2 + 12k + 4 \\ &= 3(3k^2 + 4k + 1) + 1, \end{aligned}$$

which is not divisible by 3.

Hence the contrapositive is true.

Hence the original statement is true.

**3.19 (a)** This statement is false.

For example,  $-4 < 3$ , but  $(-4)^2 \not\leq 3^2$ .

**(b)** This statement is false.

For example, if  $x = 1$ , then  $x^2 - x = 0$ , not 2.

**(c)** This statement is true.

One value of  $x$  satisfying  $x^2 - x = 2$  is  $x = 2$ .

**(d)** This statement is false.

$$\begin{aligned} x^2 - x = -1 &\Leftrightarrow x^2 - x + 1 = 0 \\ &\Leftrightarrow \left(x - \frac{1}{2}\right)^2 + \frac{3}{4} = 0, \end{aligned}$$

which is not possible for any real  $x$ .

**(e)** This statement is false.

For example, if  $x = y = 1$ , then  $x/y$  and  $y/x$  are both the integer 1.

**(f)** This statement is true.

We prove it by mathematical induction.

Let  $P(n)$  be the statement

$$1^2 + 2^2 + \dots + n^2 = \frac{1}{6}n(n+1)(2n+1).$$

Then  $P(1)$  is true, since

$$\frac{1}{6} \times 1 \times (1+1)(2+1) = \frac{2 \times 3}{6} = 1 = 1^2.$$

Assume that  $P(k)$  is true:

$$1^2 + 2^2 + \dots + k^2 = \frac{1}{6}k(k+1)(2k+1).$$

We wish to deduce that  $P(k+1)$  is true:

$$\begin{aligned} 1^2 + 2^2 + \dots + (k+1)^2 \\ = \frac{1}{6}(k+1)(k+2)(2k+3). \end{aligned}$$

Now,

$$\begin{aligned} 1^2 + 2^2 + \dots + k^2 + (k+1)^2 \\ = \frac{1}{6}k(k+1)(2k+1) + (k+1)^2 \quad (\text{by } P(k)) \\ = \frac{1}{6}(k+1)(k(2k+1) + 6(k+1)) \\ = \frac{1}{6}(k+1)(2k^2 + 7k + 6) \\ = \frac{1}{6}(k+1)(k+2)(2k+3). \end{aligned}$$

Hence

$$P(k) \Rightarrow P(k+1), \text{ for } k \geq 1.$$

Hence, by mathematical induction,  $P(n)$  is true for  $n = 1, 2, \dots$

**(g)** Let  $P(n)$  be the statement

$$\left(1 - \frac{1}{2}\right) \left(1 - \frac{1}{3}\right) \cdots \left(1 - \frac{1}{n}\right) = \frac{1}{2n}.$$

Then  $P(2)$  is false, since

$$1 - \frac{1}{2} \neq \frac{1}{4}.$$

Hence the statement is false.

(In fact, as you can check,

$$P(k) \text{ is true} \Rightarrow P(k+1) \text{ is true, for } k \geq 2;$$

that is, step 2 of a proof by mathematical induction works, even though step 1 does not.

The correct expression for the product is  $1/n$ .)

**4.1 (a)** By Theorem 4.1, the coefficient of  $a^5b^4$  in  $(a+b)^9$  is

$$\binom{9}{4} = \frac{9!}{4!5!} = \frac{9 \times 8 \times 7 \times 6}{4 \times 3 \times 2 \times 1} = 126.$$

**(b)** By Theorem 4.1, the term involving  $x^4$  in  $(1+2x)^5$  is

$$\begin{aligned} \binom{5}{4} 1^1 \times (2x)^4 &= \frac{5!}{4!1!} \times 2^4 x^4 \\ &= (5 \times 16)x^4 \\ &= 80x^4, \end{aligned}$$

so the required coefficient is 80.

**4.2 (a)** By Theorem 4.1, with  $b$  replaced by  $-b$ ,

$$\begin{aligned} (a-b)^n &= (a+(-b))^n \\ &= \binom{n}{0} a^n + \binom{n}{1} a^{n-1}(-b) + \cdots \\ &\quad + \binom{n}{k} a^{n-k}(-b)^k + \cdots + \binom{n}{n} (-b)^n \\ &= \binom{n}{0} a^n - \binom{n}{1} a^{n-1}b + \cdots \\ &\quad + (-1)^k \binom{n}{k} a^{n-k}b^k + \cdots + (-1)^n \binom{n}{n} b^n. \end{aligned}$$

**(b)** If  $a = 1$  and  $b = 1$ , then  $a - b = 0$ , so we obtain

$$\begin{aligned} 0 &= \binom{n}{0} - \binom{n}{1} + \cdots + (-1)^k \binom{n}{k} + \cdots \\ &\quad + (-1)^n \binom{n}{n}. \end{aligned}$$

For  $n = 4$ , this identity is

$$\begin{aligned} 0 &= \binom{4}{0} - \binom{4}{1} + \binom{4}{2} - \binom{4}{3} + \binom{4}{4} \\ &= 1 - 4 + 6 - 4 + 1 \\ &= 0, \end{aligned}$$

as expected.

**4.3 (a)** For  $n = 5$ , the Geometric Series Identity is

$$a^5 - b^5 = (a-b)(a^4 + a^3b + a^2b^2 + ab^3 + b^4).$$

**(b)** If  $n$  is an odd positive integer, then

$$(-b)^n = (-1)^n b^n = -b^n,$$

so

$$a^n - (-b)^n = a^n + b^n.$$

By Theorem 4.2,

$$\begin{aligned} a^n - (-b)^n &= (a - (-b))(a^{n-1} + a^{n-2}(-b) + \cdots \\ &\quad + a(-b)^{n-2} + (-b)^{n-1}), \end{aligned}$$

so, since  $n - 1$  is even and  $n - 2$  is odd,

$$\begin{aligned} a^n + b^n &= (a+b)(a^{n-1} - a^{n-2}b + \cdots \\ &\quad - ab^{n-2} + b^{n-1}), \end{aligned}$$

as required.

For  $n = 5$ , we have

$$a^5 + b^5 = (a+b)(a^4 - a^3b + a^2b^2 - ab^3 + b^4).$$

**4.4** Using the corollary to Theorem 4.2, with  $a = 1$  and  $r = \frac{1}{2}$ , we obtain

$$\begin{aligned} 1 + \frac{1}{2} + \frac{1}{4} + \cdots + \frac{1}{2^{n-1}} &= 1 + \frac{1}{2} + \left(\frac{1}{2}\right)^2 + \cdots + \left(\frac{1}{2}\right)^{n-1} \\ &= 1 \left( \frac{1 - \left(\frac{1}{2}\right)^n}{1 - \frac{1}{2}} \right) \\ &= 2 \left( 1 - \frac{1}{2^n} \right) \\ &= 2 - \frac{1}{2^{n-1}}. \end{aligned}$$

**4.5** By the Polynomial Factorisation Theorem,  $x + 3$  is a factor of  $p(x)$  if and only if  $p(-3) = 0$ , that is,

$$\begin{aligned} 0 &= (-3)^3 + c(-3)^2 + 6(-3) + 36 \\ &= -27 + 9c - 18 + 36 \\ &= 9c - 9. \end{aligned}$$

This equation has just one solution,  $c = 1$ , so  $x + 3$  is a factor of  $p(x)$  if and only if  $c = 1$ .

**4.6 (a) (i)** Since all the roots are integers, the only possible roots are the factors of 4, that is,  $\pm 1, \pm 2, \pm 4$ . Considering these in turn, we obtain the following table.

$x$	1	-1	2	-2	4	-4
$p(x)$	2	0	0	-16	20	-108

So the only solutions are  $x = -1$  and  $x = 2$ . In fact,

$$x^3 - 3x^2 + 4 = (x+1)(x-2)(x-2).$$

**(ii)** Since all the roots are integers, the only possible roots are the factors of  $-15$ , that is,  $\pm 1, \pm 3, \pm 5, \pm 15$ . Considering these in turn, we obtain the following table.

$x$	1	-1	3	-3	5	...
$p(x)$	0	-48	0	-192	0	...

We do not need to work out any more values, as we already have three roots:  $x = 1$ ,  $x = 3$  and  $x = 5$ . So

$$x^3 - 9x^2 + 23x - 15 = (x - 1)(x - 3)(x - 5).$$

**(b)** A suitable equation is

$$(x - 1)(x - 2)(x - 3)(x + 3) = 0,$$

that is,

$$x^4 - 3x^3 - 7x^2 + 27x - 18 = 0.$$

**4.7 (a)**  $(a + 3b)^4$

$$\begin{aligned} &= \binom{4}{0} a^4 + \binom{4}{1} a^3(3b) + \binom{4}{2} a^2(3b)^2 \\ &\quad + \binom{4}{3} a(3b)^3 + \binom{4}{4} (3b)^4 \\ &= a^4 + 4a^3(3b) + 6a^2(9b^2) + 4a(27b^3) + 81b^4 \\ &= a^4 + 12a^3b + 54a^2b^2 + 108ab^3 + 81b^4 \end{aligned}$$

**(b)**  $(1 - t)^7$

$$\begin{aligned} &= \binom{7}{0} + \binom{7}{1}(-t) + \binom{7}{2}(-t)^2 \\ &\quad + \binom{7}{3}(-t)^3 + \binom{7}{4}(-t)^4 + \binom{7}{5}(-t)^5 \\ &\quad + \binom{7}{6}(-t)^6 + \binom{7}{7}(-t)^7 \\ &= 1 - 7t + 21t^2 - 35t^3 + 35t^4 - 21t^5 + 7t^6 - t^7 \end{aligned}$$

**4.8 (a)** The coefficient of  $a^3b^7$  is

$$\binom{10}{7} = \frac{10 \times 9 \times 8}{3 \times 2} = 120.$$

**(b)** The coefficient of  $x^{13}$  is

$$\binom{15}{13} 2^2 = \frac{15 \times 14}{2} \times 4 = 420.$$

**4.9 (a)** This is a geometric series with  $a = 3$ ,  $r = -\frac{1}{3}$  and  $n = 12$  terms, so its sum is

$$\begin{aligned} 3 \frac{1 - (-\frac{1}{3})^{12}}{1 - (-\frac{1}{3})} &= 3 \times \frac{3}{4} (1 - (\frac{1}{3})^{12}) \\ &= \frac{9}{4} (1 - (\frac{1}{3})^{12}) \\ &\simeq 2.25. \end{aligned}$$

**(b)** This is a geometric series with first term 1, common ratio  $r = \frac{a}{b} \neq 1$  and  $n + 1$  terms, so its sum is

$$\frac{1 - (\frac{a}{b})^{n+1}}{1 - (\frac{a}{b})} = \left( \frac{b}{b-a} \right) \left( 1 - (\frac{a}{b})^{n+1} \right).$$

**4.10 (a)** Putting  $x = 2$ , we obtain

$16 + 4 - 26 + 6 = 0$ , so  $x - 2$  is a factor. Hence

$$\begin{aligned} 2x^3 + x^2 - 13x + 6 &= (x - 2)(2x^2 + 5x - 3) \\ &= (x - 2)(x + 3)(2x - 1). \end{aligned}$$

**(b)** Trying integer values which are factors of 10, we find that  $x = 1$  is a root, so  $x - 1$  is a factor. Hence

$$\begin{aligned} x^3 + 6x^2 + 3x - 10 &= (x - 1)(x^2 + 7x + 10) \\ &= (x - 1)(x + 2)(x + 5), \end{aligned}$$

so the solutions of  $x^3 + 6x^2 + 3x - 10 = 0$  are 1,  $-2$  and  $-5$ .

**(c)**  $x^2 + x = y^2 + y \Leftrightarrow x^2 - y^2 + x - y = 0$ .

We note that  $x = y$  is a solution, so  $x - y$  is a factor. Hence

$$x^2 - y^2 + x - y = (x - y)(x + y + 1),$$

so  $x = y$  or  $x = -y - 1$ .

**4.11 (a)** If the sum of the roots is 0 and the product is  $-30$ , then the cubic polynomial must be of the form

$$x^3 + cx + 30, \quad \text{for some } c \in \mathbb{R}.$$

If  $x = 3$  is a root, then

$$27 + 3c + 30 = 0,$$

so  $c = -19$ .

Hence the polynomial is  $x^3 - 19x + 30$ .

**(b)** We know that  $x - 3$  is a factor. Hence

$$\begin{aligned} x^3 - 19x + 30 &= (x - 3)(x^2 + 3x - 10) \\ &= (x - 3)(x - 2)(x + 5), \end{aligned}$$

so the other two roots are 2 and  $-5$ .